

0 896 85

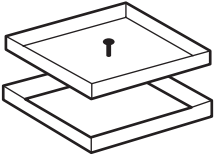

0 896 86

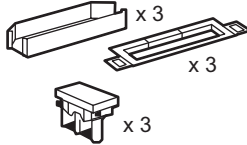
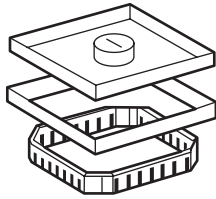

M4 x 10 (x4)

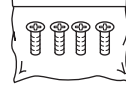

0 896 88

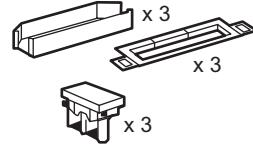
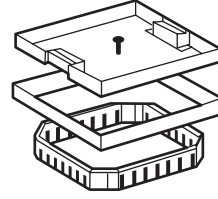
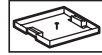

M4 x 10 (x4)

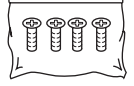

1

0 896 34

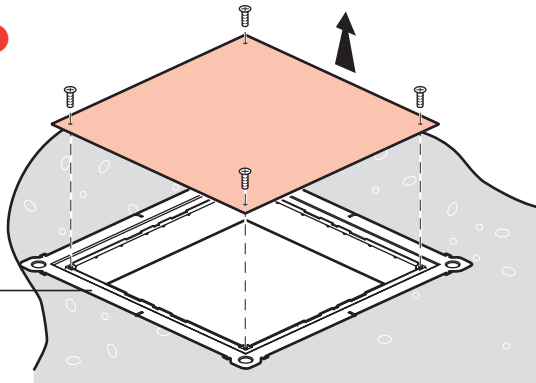

0 896 83

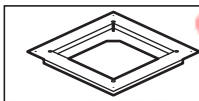

M4 x 45 (x4)
M6 x 40 (x4)

0 896 84

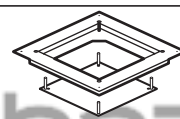

M4 x 45 (x4)
M6 x 70 (x4)
M6 x 100 (x4)

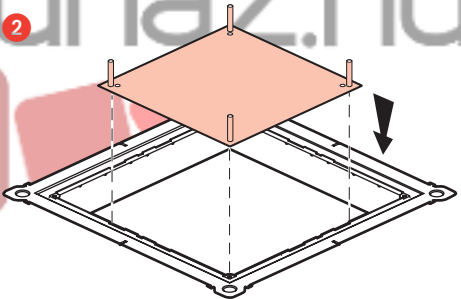

2

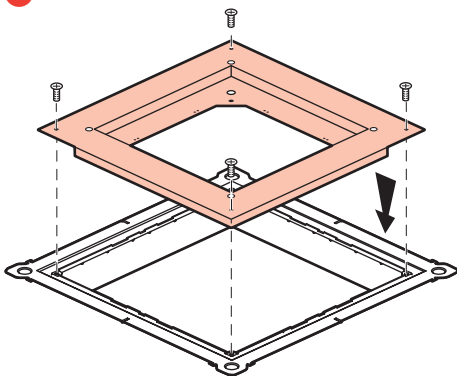

M6 x 40 (x4)

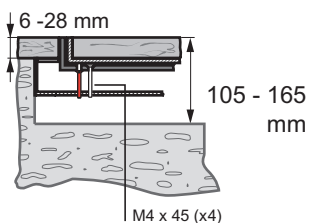

3

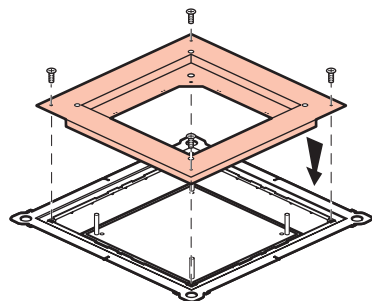

M6 x 70 (x4)

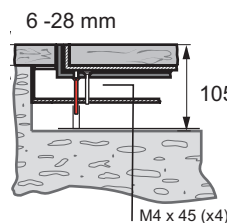

M6 x 100 (x4)

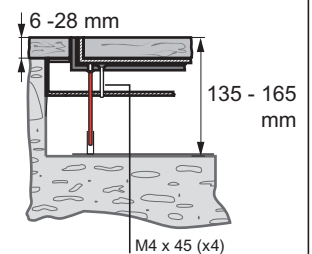

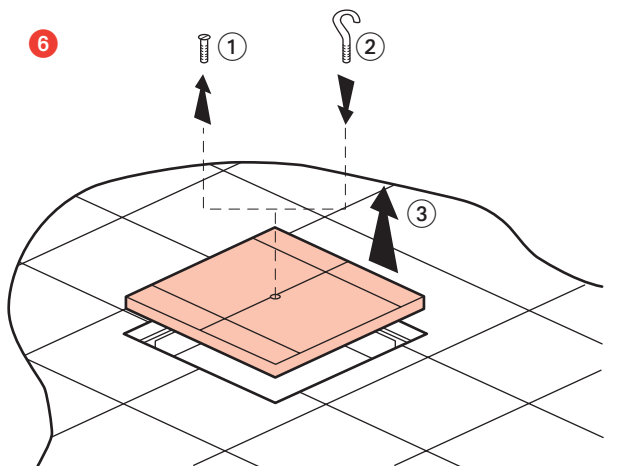
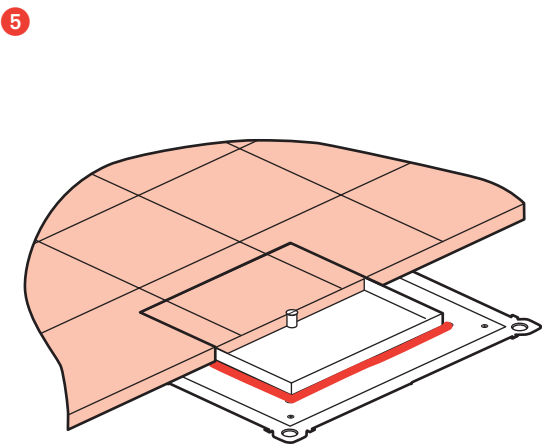
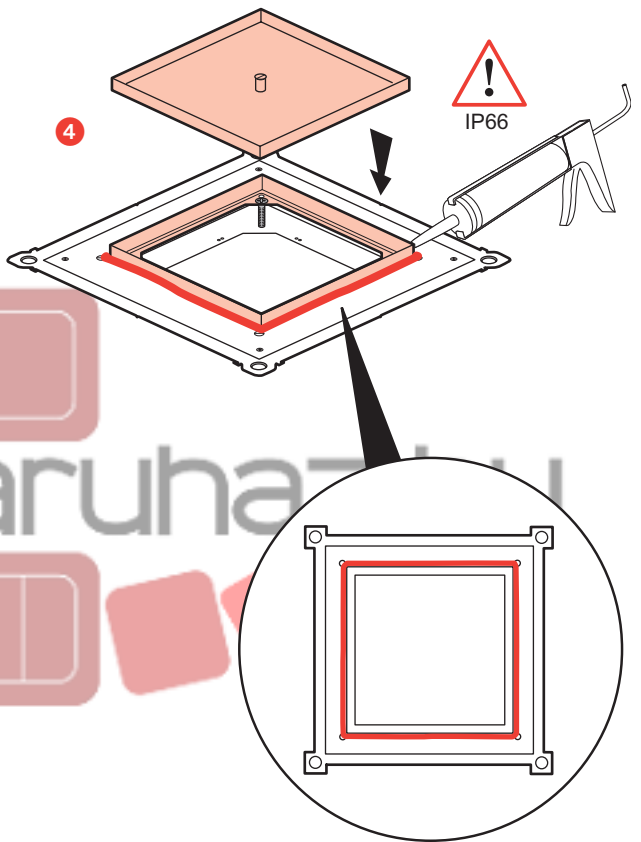
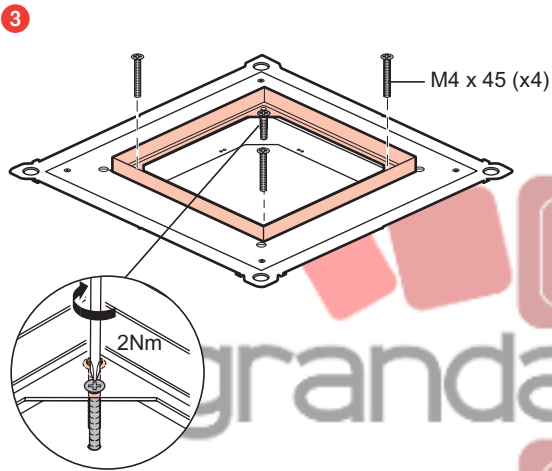
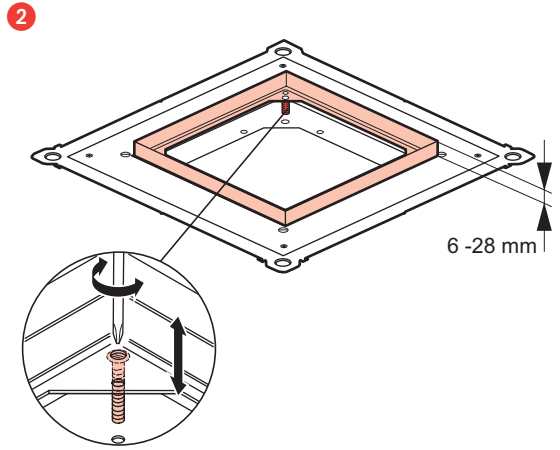
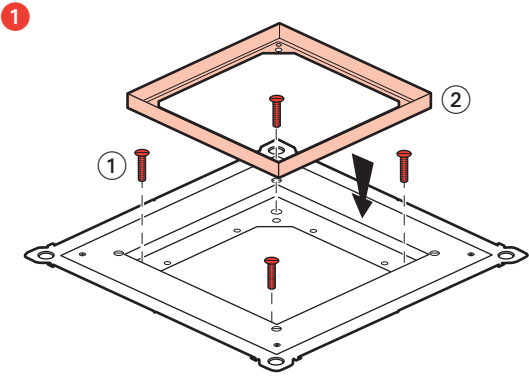
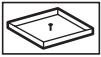

0 896 86



0 896 88

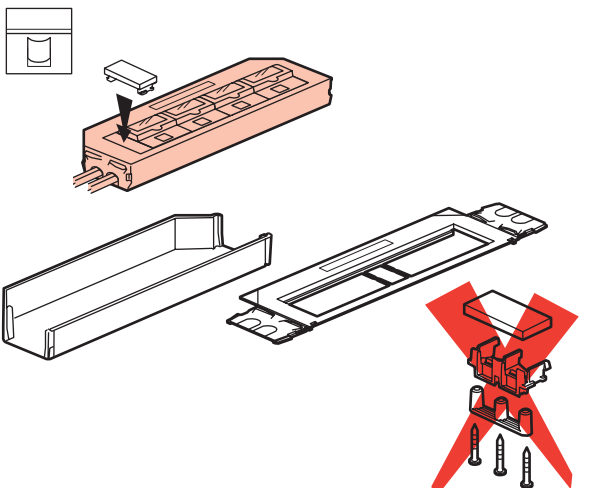
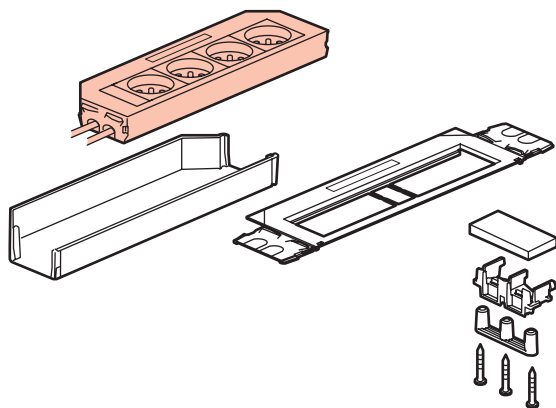
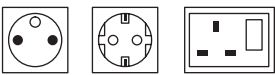
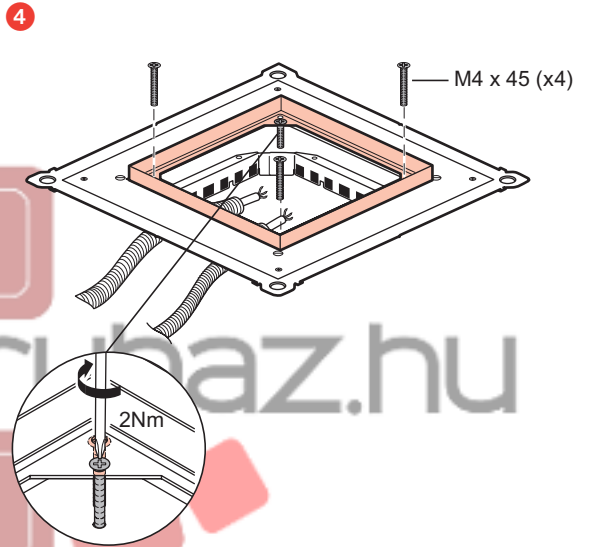
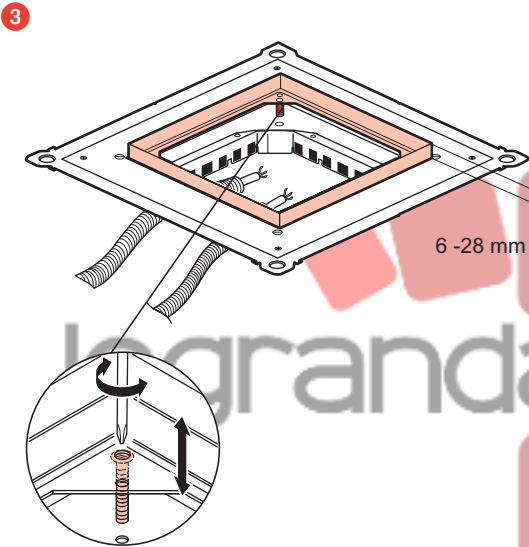
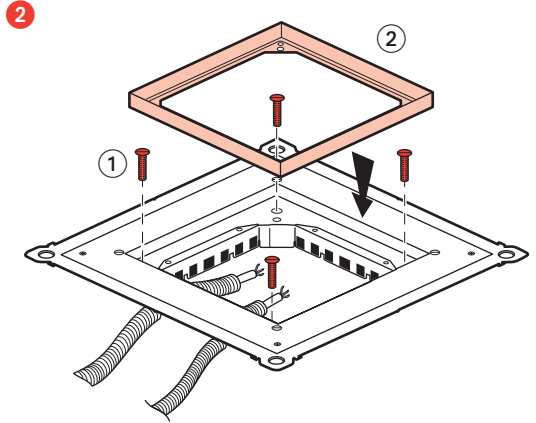
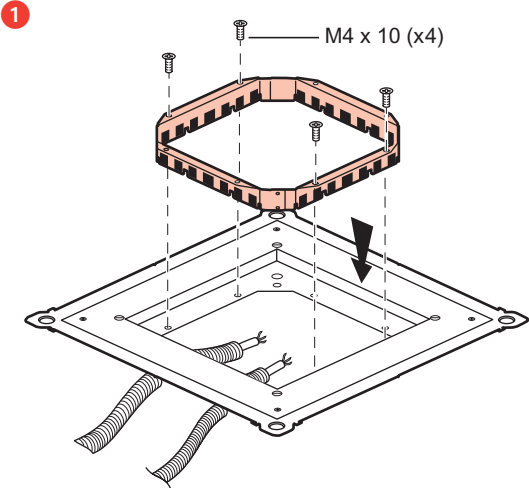
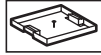

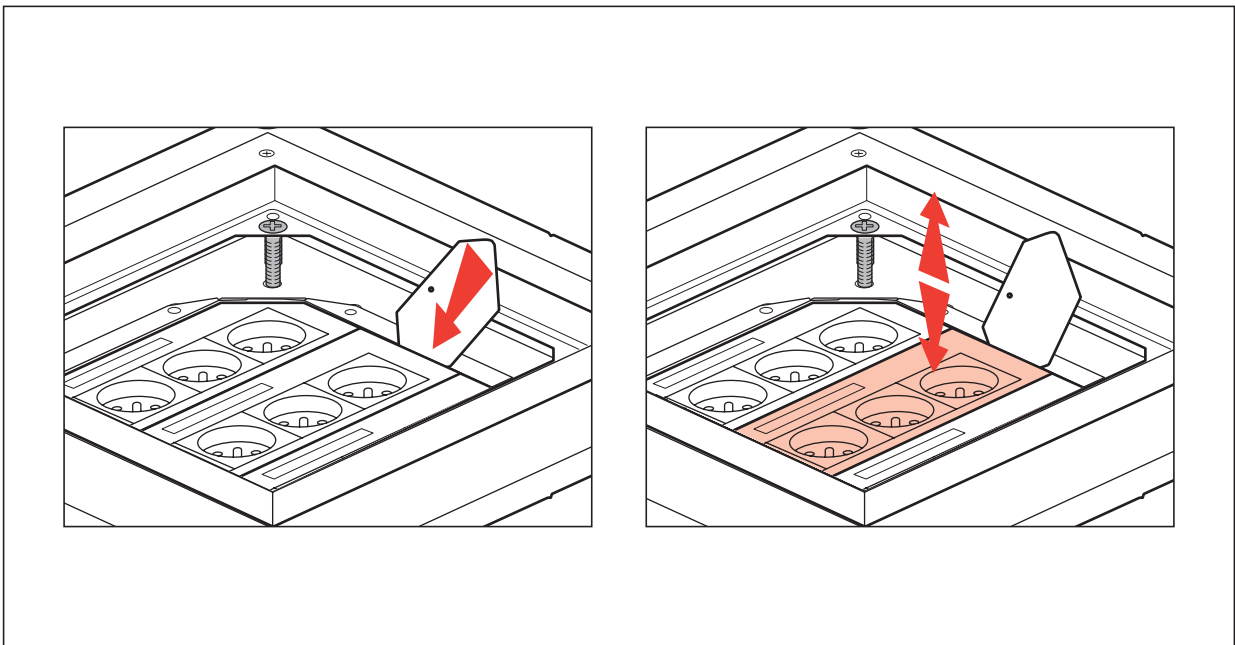
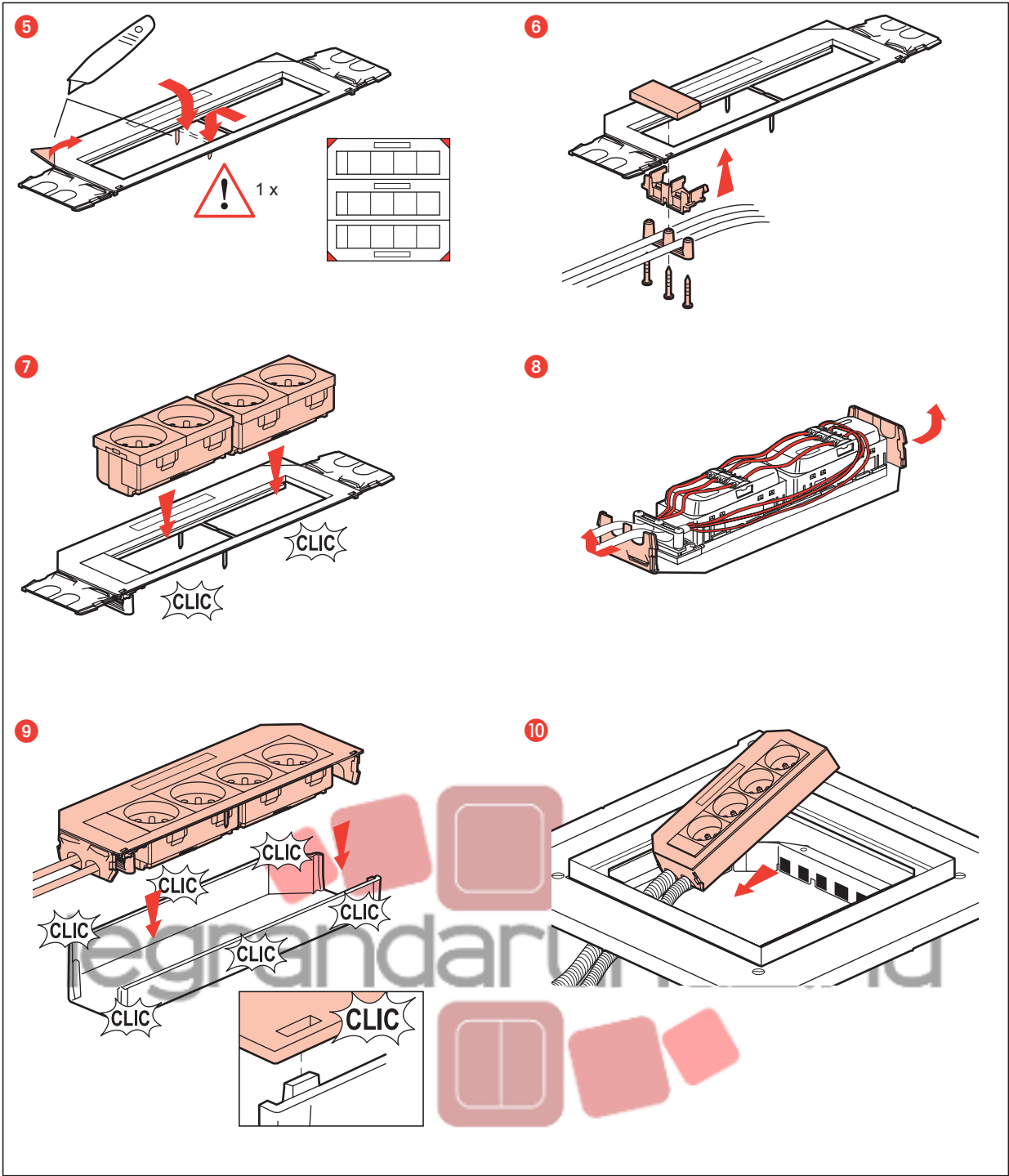

0 896 86



11

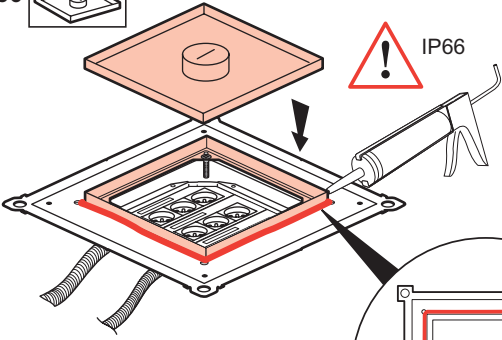

12

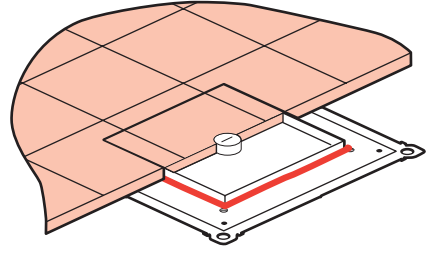

13

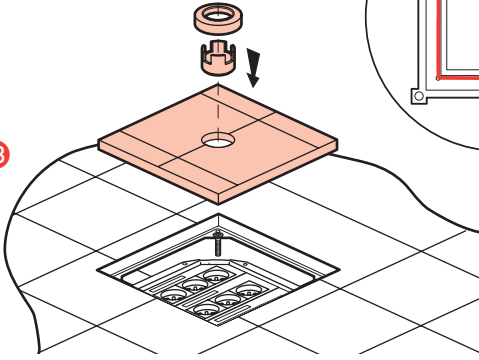

14

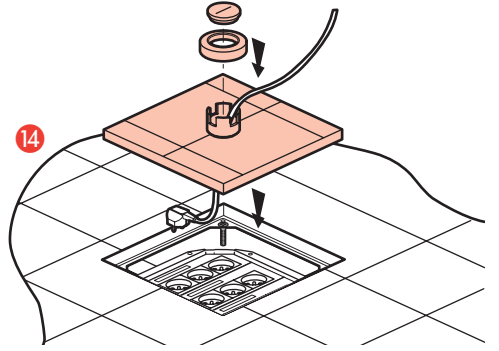

15

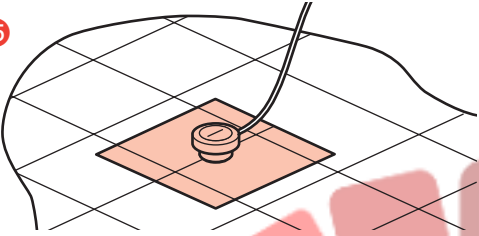

0 896 88

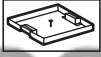

11

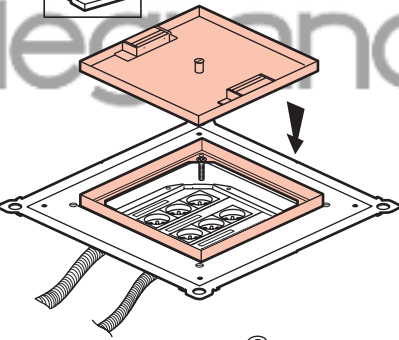

12

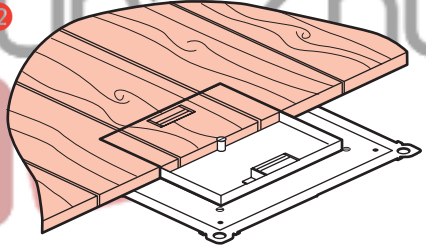

13

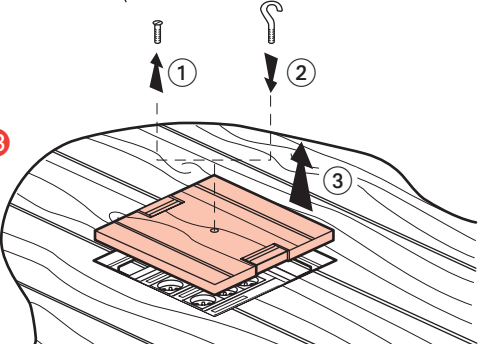

14

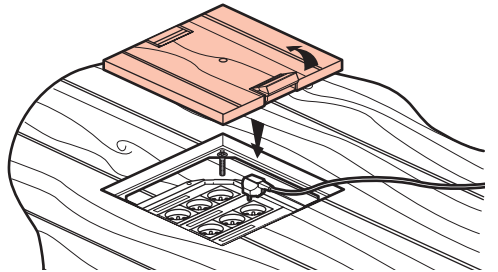

15

