

**Incara™  
 Tower 120**

Cat. No(s) : 6 549 80/81/82/83

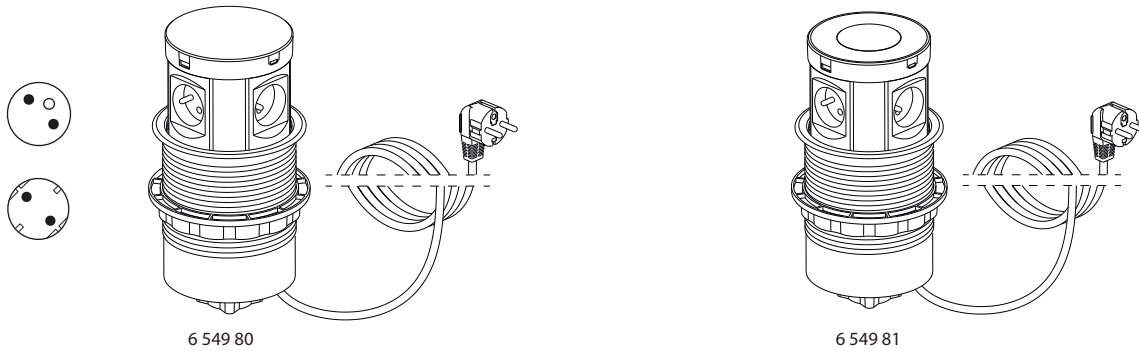

**1. USE**

Incara™ Tower 120 is a 360° retractable electrification solution dedicated to meeting room table. It provides 4 power sockets and 4 USB chargers distributed around the product. An optional wireless charging solution is also available.

**2. RANGE**

Incara™ Towers 120 with 2 m cord			Standards	
			French	Schuko
4x 2P+E	2 USB A+C 15 W	-	6 549 80	6 549 82
		wireless charger	6 549 81	6 549 83

**3. DIMENSIONS**

■ 3.1 Overall dimensions

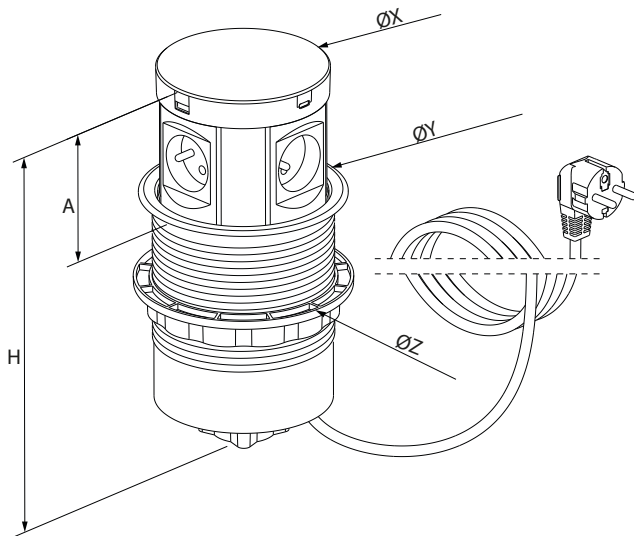

Cat. Nos	H	A	ØX	ØY	ØZ
6 549 80/81/82/83	271.7	92.5	115	138	145

■ 3.2 Product installed & in opened position on table

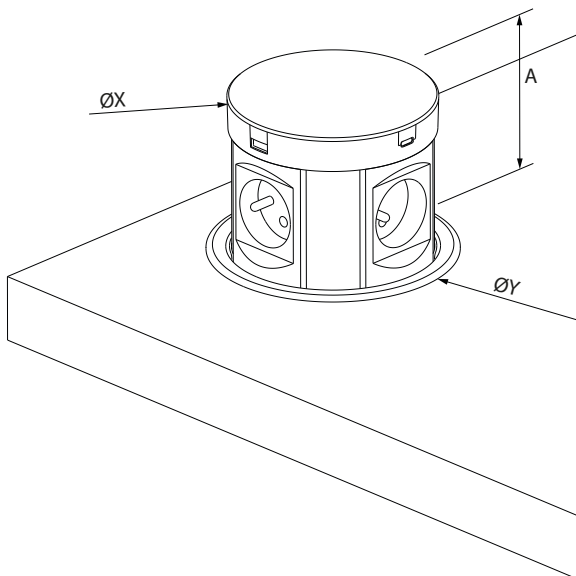

Cat. Nos	A	ØX	ØY
6 549 80/81/82/83	92.5	115	138

**3. DIMENSIONS (cont.)**

■ 3.3 Product installed & in opened or closed position under table

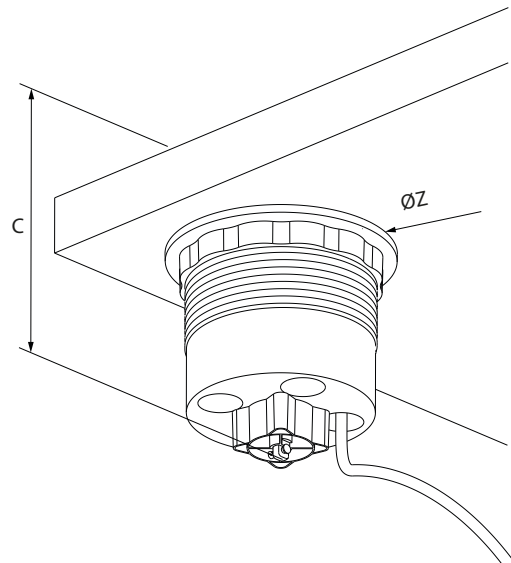

Cat. Nos	C	ØZ
6 549 80/81/82/83	181.7	145

3.4. Product installed and in closed position on table

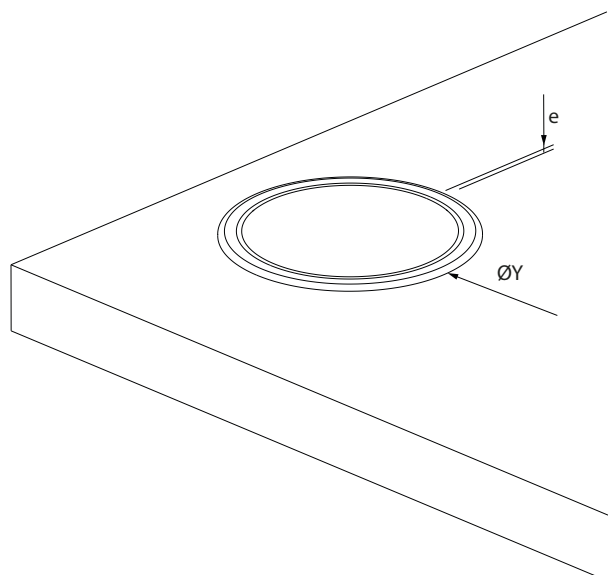

Cat. Nos	ØY	e
6 549 80/81/82/83	138	2.5

## 4. INSTALLATION

Must not be fitted on the floor

### ■ 4.1 Installation into the desk

#### 4.1.1 Drilling dimensions

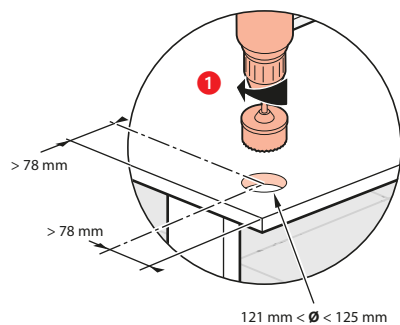
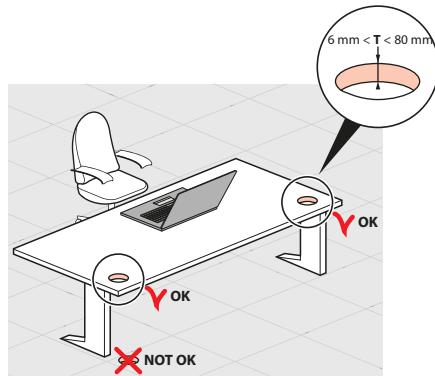

#### 4.1.2 Use

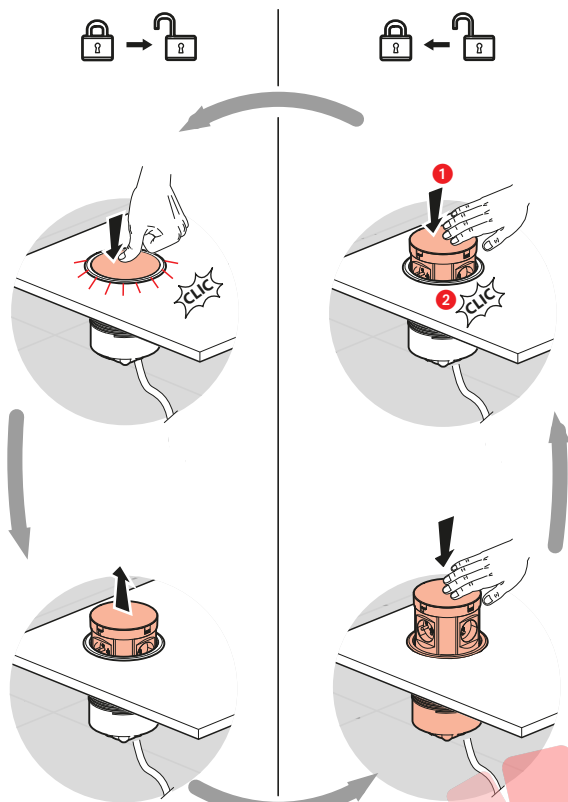

## 5. TECHNICAL CHARACTERISTICS

### ■ 5.1 Mechanical characteristics

Resistance to Impact: IK 06

Degree of protection provided by enclosures: IP 20

### ■ 5.2 Caractéristiques matières

Body: anodised aluminium

Plastic parts: PA

Upper surface: glass for cat. no 6 549 81

### ■ 5.3 Electrical characteristics

#### 5.3.1. 2 P+E sockets characteristics

- Supply voltage: 16A-250V~ 3680W Max

- Frequency: 50/60 Hz

#### 5.3.2 USB charger type: there are 2

Trade mark	legrand®
Address	128, av. du Maréchal-de-Lattre-de-Tassigny - 87045 LIMOGES Cedex Tel. : 0 (+33) 5 55 06 87 87 - Fax : 0 (+33) 5 55 06 88 88 www.legrand.com
Input voltage	220-250V
Input AC frequency	50-60Hz
Output voltage	5,0V
Output current	3,1A
Output power	15,5W
Average active efficiency	82,3%
Efficiency at low load (10%)	82,1%
No-load power consumption	0,04W

#### 5.3.3 Wireless charger characteristics

5W max

#### 5.3.4 Cords characteristics

H05VV-F 3G 1.5mm<sup>2</sup>

### ■ 5.4 Climate characteristics

Operating temperature: from -5°C to +35°C

Storage temperature: from -10°C to +70°C

## 6. SAVE

Superficial cleaning with a soft cloth. Do not use abrasive products or detergents.

**Caution:** Always test before using other special cleaning products

## 7. STANDARDS & APPROVALS

Compliant to:

Standards	
French	Schuko
NF C61-314 and IEC 60884-1	IEC 60884-1

USB chargers compliant to IEC 62368-1

Products should be installed by competent persons to the current version of the local wiring regulations.

Please consult Legrand locally for further details.